

Diamond & Borazon Grinding Bottoming Pins

The BH Series are manufactured for BOTTOMING and SHOULDER Grinding. They have a back taper, recessed center, and grinding dust exit slots. Two types are provided. Type A for diameters .315" to .473" and Type B for sizes .591" to 1.00".

Because there is no proven advantage to carbide in this application, the shanks of Titan Bottoming Pins are made from steel. The 1/4" and 3/8" diameter sizes are hardened up to 58-60 Rockwell C Scale. Maximum rigidity and safety are thus provided for the work to be performed. All shanks are centerless ground to .0005" concentricity + .0000" to - .0002".

Combined with Titan's famous CHROME-LOK Bond and 35+ years experience in electro-plated pins, this offers unique advantages. Because 75% of the individual grain size is exposed for grinding purposes, a feature pioneered by Titan, and directly proportional to grinding life. They never need dressing for wear, enabling the pins to cut faster and cooler with minimal clogging. These features, together with the rigid concentricity, size and hardness control of Titan's steel shanks, permit faster feeds a capability which can be utilized.

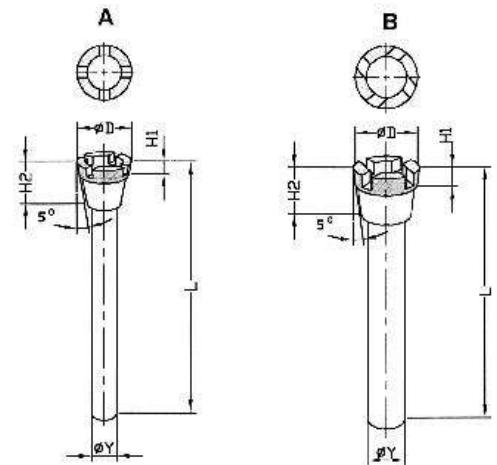

Order #	Diameter "D"	Abrasive Length "H1"	Head Length "H2"	Overall Length "L"	Shank Diameter	Type
2909BH	0.315"	0.155"	0.414"	2.500"	1/4"	A
2910FBH	0.335"	0.087"	0.414"	2.500"	1/4"	A
2911BH	0.394"	0.093"	0.414"	2.500"	1/4"	A
2913BH	0.473"	0.143"	0.414"	2.500"	1/4"	A
2915XLBH	0.591"	0.112"	0.482"	2.500"	3/8"	B
2917XLBH	0.730"	0.112"	0.610"	2.500"	3/8"	B
2919XLBH	1.000"	0.112"	0.770"	2.500"	3/8"	B

Diamond Bottoming Grinding Pins Available in 80/100 Grit Only

Order #	Diameter "D"	Abrasive Length "H1"	Head Length "H2"	Overall Length "L"	Shank Diameter	Type
6909BH	0.315"	0.155"	0.414"	2.500"	1/4"	A
6910FBH	0.335"	0.087"	0.414"	2.500"	1/4"	A
6911BH	0.394"	0.093"	0.414"	2.500"	1/4"	A
6913BH	0.473"	0.143"	0.414"	2.500"	1/4"	A
6915XLBH	0.591"	0.112"	0.482"	2.500"	3/8"	B
6917XLBH	0.730"	0.112"	0.610"	2.500"	3/8"	B
6919XLBH	1.000"	0.112"	0.770"	2.500"	3/8"	B

Borazon Bottoming Grinding Pins Available in 100/120 Grit Only

www.TitanToolSupply.com • Phone: 716-873-9907